

Pressure-reducing valve 5801

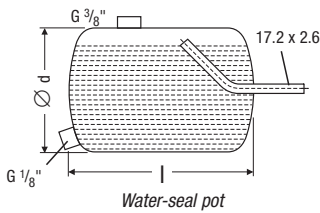

Water-seal pot

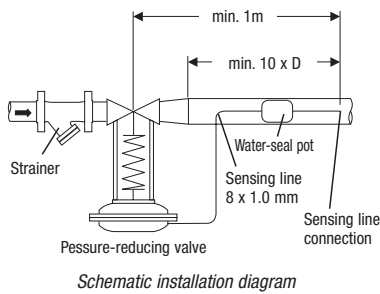

Schematic installation diagram

### Application

**Type 5801** Pressure-reducing valve for use with steam and other fluids.  
In all energy and process systems.

### Design

The pressure-reducing valve is a balanced single-seat proportional controller operating without auxiliary energy.  
The pressure-reducing valve consists of a body with internals, bellows, spring, handwheel and actuator. For steam and liquids at temperatures above 100 °C a water-seal pot is required to protect the actuator diaphragm.

### Dimensions [mm] and Weights [kg] of Valve Body

DN	15	20	25	32	40	50	65	80	100	125	150	200
L	130	150	160	180	200	230	290	310	350	400	480	600
H	390	390	390	408	425	500	505	590	590	705	725	760
Weight 0.7043	7	8	9	12	14	18	26	40	50	77	112	170
Weight 1.0619	7	8	9	12	14	19	27	40	54	82	115	176
Weight 1.4581	7	8	9	12	14	19	27	40	54	82	115	176

### Dimensions [mm] and Weights [kg] of Actuator

Actuator	A11	A2	A3	A4	A51	A61	B11	B2
Ø A	150	160	195	270	355	510	150	160
h <sub>1</sub>	90	100	100	120	165	200	90	110
Approx. weight	2.8	4.5	6.0	4.5	10	27.5	3.5	5.5

### Dimensions [mm] and Weights [kg] of Water Pot Seal

Size	l	d	Size DN	Weight
1	206	88.9	15 – 65	1.7
2	172	152.4	80 – 100	3.5
3	250	152.4	125 – 200	4.9

### Schematic Representation of a Compact-Design Pressure Reducing Station

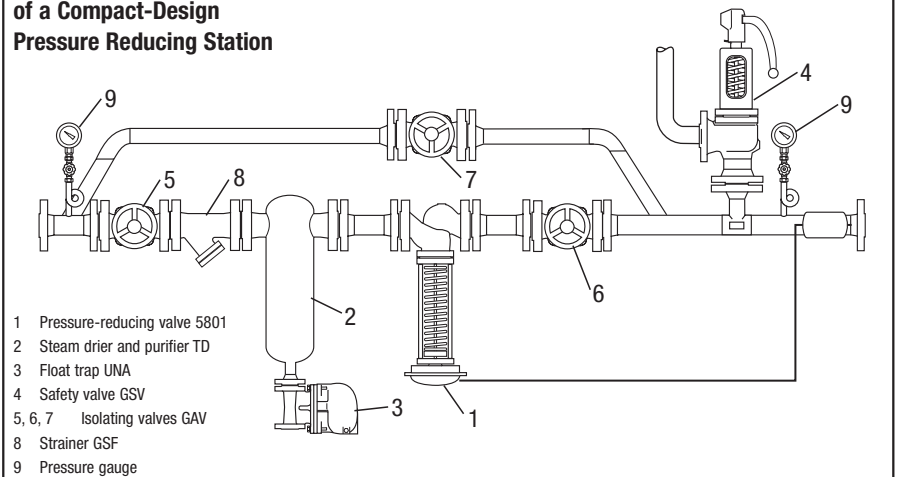

- 1 Pressure-reducing valve 5801
- 2 Steam drier and purifier TD
- 3 Float trap UNA
- 4 Safety valve GSV
- 5, 6, 7 Isolating valves GAV
- 8 Strainer GSF
- 9 Pressure gauge