



GESTRA® Steam Traps · Product Range A1

UNA 14
UNA 16
UNA 16A

Ball Float Trap 14, PN 25, UNA 16 Carbon Steel, PN 40, UNA 16A Stainless Steel, PN 40 DN 15, 20, 25

Description

UNA 14, UNA 16, UNA 16A are ball float steam traps with rolling ball valve. The steam traps can be used for all operating conditions, as they are unaffected by back pressure. They consist of a body with bolted cover and a control unit. The control unit is freely accessible after removing the cover. It can be completely replaced without having to remove the valve body from the line. A conversion of "h" design to "v" design or vice versa is possible without any problem by repositioning body and control unit. The direction of flow is indicated by an arrow, the position of installation by the word "Top" on the name plate.

- suitable for large condensate flowrates
 - "h"-design for horizontal lines
 - "v"-design for vertical lines
- (To convert "h" to "v" design or vice versa turn cover and control unit respectively)

UNA 14, UNA 16, UNA 16A

The following three different types of control units are available: Control unit "SIMPLEX": level-dependent float control particularly suitable for cold condensate. Control unit "SIMPLEX R": level-dependent float control with internal vent pipe for continuous air-venting. Control unit "DUPLEX": float control with temperature-dependent automatic air-venting of saturated steam systems.

Pressure / Temperature Rating (DIN 1092-1) UNA 14 S.G. (ductile) iron (3 E0), PN 25					
Max. allowable pressure PMA	[bar]	25	19.4	17.8	15
Max. allowable temperature TMA	[°C]	20	200	250	350
Maximum differential pressure Δ PMX (inlet pressure minus outlet pressure)	[bar]	13 or 4*)			

Pressure / Temperature Rating (DIN 1092-1) UNA 16 carbon steel (3 E0), PN 40					
Max. allowable pressure PMA	[bar]	40	30.2	25.8	23.1
Max. allowable temperature TMA	[°C]	20	200	300	400
Maximum differential pressure Δ PMX (inlet pressure minus outlet pressure)	[bar]	22, 13 or 4*)			

Pressure / Temperature Rating UNA 16 carbon steel, CLASS 150					
Max. allowable pressure PMA	[bar]	17.3	13.8	10.2	6.5
Max. allowable temperature TMA	[°C]	20	200	300	400
Maximum differential pressure Δ PMX (inlet pressure minus outlet pressure)	[bar]	13 or 4*)			

Pressure / Temperature Rating (DIN 1092-1) UNA 16A stainless steel (13 E0), PN 40					
Max. allowable pressure PMA	[bar]	40	35.6	29.3	25.8
Max. allowable temperature TMA	[°C]	20	100	200	300
Max. low temperature (until PN)	[°C]	-196			
Maximum differential pressure Δ PMX (inlet pressure minus outlet pressure)	[bar]	22, 13 or 4*)			

Pressure / Temperature Rating UNA 16A (stainless steel), CLASS 150					
Max. allowable pressure PMA	[bar]	19.3	17.0	14.0	10.2
Max. allowable temperature TMA	[°C]	20	100	200	300
Maximum differential pressure Δ PMX (inlet pressure minus outlet pressure)	[bar]	22, 13 or 4*)			

Pressure/temperature ratings according to type of connection!

*) Depending on orifice (O)

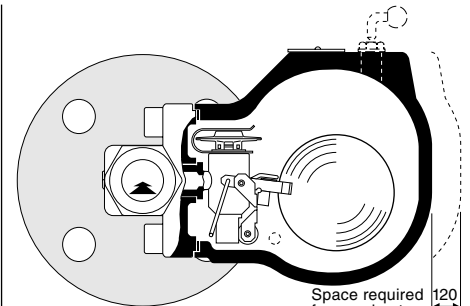

UNA 14h/UNA 16h (horizontal)
Duplex design

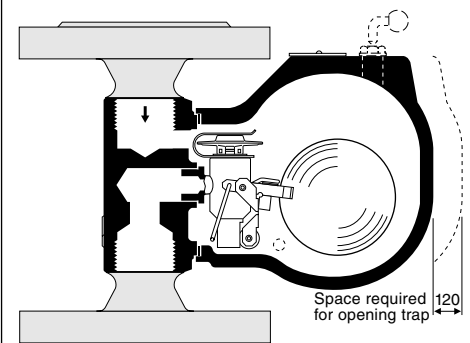

UNA 14v/UNA 16v (vertical)
Duplex design

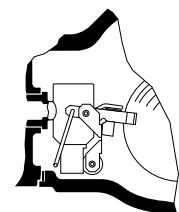

UNA 14/UNA 16 Simplex design

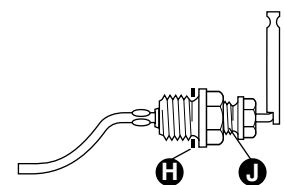

Float-lifting lever (optional extra)

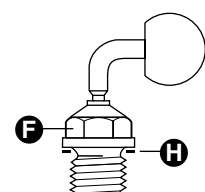

Hand vent valve (optional extra)

Materials	DIN EN	DIN	ASTM
Body UNA 14, 14 P, 16	P250GH (1.0460)	C 22.8 (1.0460)	A 105
Cover UNA 14	EN-GJS-400-18-LT (EN-JS-1049)	GGG 40.3 (0.7043)	A 536 60-40-18 ¹⁾
Cover UNA 16	GP240GH (1.0619)	GS-C 25 (1.0619)	A 216 WCB
Body UNA 16A, stainless steel	X2CrNiMo17-12-2 (1.4404)	X 2 CrNiMo 17 13 2 (1.4404)	A 182 F 316 L
Cover UNA 16A, stainless steel	G-X5CrNi19-10 (1.4308)	G-X 6 CrNi 18 9 (1.4308)	A 351 CF 8 ¹⁾
Fixing studs UNA 14, 14 P, 16	42CrMo4 (1.7225)		A 193 B7
Fixing studs UNA 16A, stainless steel	X6NiCrTiMoVB25-15-2 (1.4980)	X 5 NiCrTi 26 15 (1.4980)	
Ball float	X6CrNiMoTi17-12-2 (1.4571)	X 6 CrNiMoTi 17 12 2 (1.4571)	A 182 F 316 ¹⁾
Seat	X8CrNiS18-9 (1.4305)	X 10 CrNiS 18 9 (1.4305)	AISI 303 ¹⁾
Ball valve	X5CrNi18-10 (1.4301)	X 5 CrNi 18 10 (1.4301)	A 182 F 304 ¹⁾
Cover gasket	Graphite-CrNi		
Thermostatic capsule 5N2	Hastelloy/stainless steel		
Other internals	Stainless steel		

¹⁾ Physical and chemical properties comply with DIN grade.
ASTM nearest equivalent grade is stated for guidance only.

Design

Body with bolted cover. The control unit is freely accessible after removing the cover. The control unit can be replaced without having to remove the body from the line.

"h"-type for installation in horizontal pipework, flow from left to right (seen from the cover side). Conversion to obtain flow from right to left possible.

"v"-type for installation in vertical pipework with downward flow.

The traps can be supplied with different control units:

■ **Duplex:** Float control with temperature-dependent automatic air-venting: GESTRA thermostatic capsule "5N2".

■ **Simplex:** Float control specially suited for the discharge of cold condensates and distillates.

■ **Simplex-R:** Float control with internal vent pipe for continuous air-venting.

Optional extra:

- Purging device (float lifting lever).
- Vent hole 3/8" BSP for connecting an air-balance pipe.
- Hand-vent valve 3/8" BSP.

Connections

UNA 14

- Flanges: DIN, PN 25
- Screwed sockets: BSP and NPT threads

UNA 16, 16A

- Flanges: DIN, PN 40 and ASME Class 150
- Screwed sockets: BSP and NPT threads
- Socket-weld ends
- Butt-weld ends

Dimensions

Nominal sizes DN	[mm]	15	20	25
	[inch]	½	¾	1
UNA 14 h/v overall length	L ¹⁾			
Screwed BSP/NPT		95	95	95
Flanged DIN EN 1092-1		150	150	160
UNA 16 h/v overall length	L ¹⁾			
Screwed sockets		95	95	95
Flanged DIN EN 1092-1		150	150	160
Flanged ASME		150	150	160
Socket-weld ends		95	95	95
Butt-weld ends		200	200	200
Flange dimensions DIN EN 1092-1	D	95	105	115
	b	16	18	18
	k	65	75	85
	g	45	58	68
	l	14	14	14
Number of holes		4	4	4
Weight				
Flange	[kg]	6.0	6.5	7.0
Screwed sockets, socket-weld ends, butt-weld ends	[kg]	4.5	4.5	4.5

¹⁾ Overall length of flanged traps according to DIN EN 26554 (ISO 6554) series 1

UNA 14h / UNA 16h

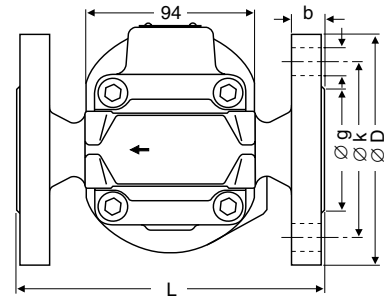
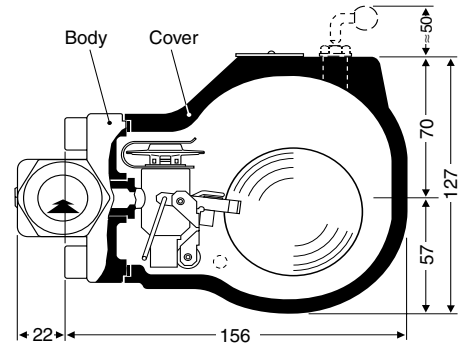

UNA 14h / UNA 16h, flanged design

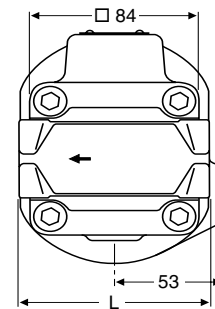

UNA 14h, with screwed sockets
UNA 16h, with screwed sockets and
socket-weld ends

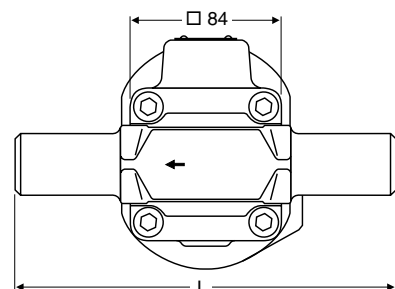

UNA 16h, with butt-weld ends

UNA 14v / UNA 16v

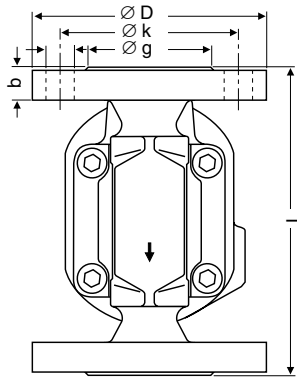
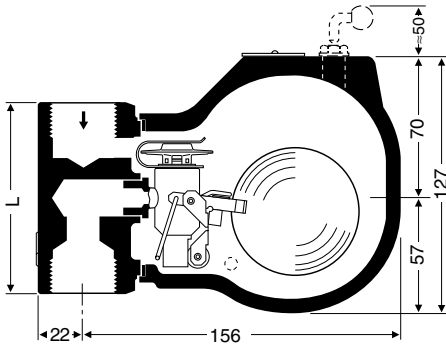

UNA 14h / UNA 16v, flanged design

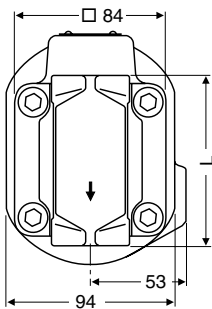

UNA 14v, with screwed sockets
UNA 16v, with screwed sockets and
socket-weld ends

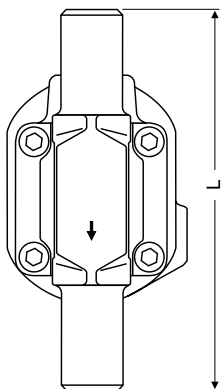

UNA 16v, with butt-weld ends

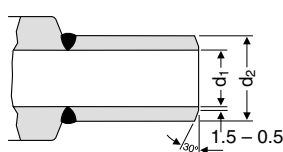

Butt-weld ends
(UNA 16)

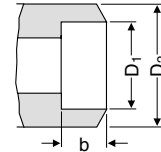

Socket-weld ends
(UNA 16)

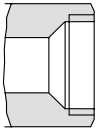

Screwed sockets
(UNA 14, UNA 16)

Dimensions	DN	15			20			25		
		D ₁	D ₂	b	D ₁	D ₂	b	D ₁	D ₂	b
Socket-weld ends										
	[mm]	22	32	10	27	38	13	34	44	13
Butt-weld ends										
	[mm]	d ₁	d ₂		d ₁	d ₂		d ₁	d ₂	
		17	22		22	28		28,5	34	
for connecting tube	[mm]	21.3 x 2.0			26.9 x 2.3			33.7 x 2.6		

Spare Parts

Item	Designation	Stock code	Stock code	
		UNA 14	UNA 16 UNA 16A S.S.	
H	Gasket ²⁾ A 17 x 23	560486	560486 560514	
O	Cover gasket ¹⁾ (graphite/CrNi) 67 x 77 x 1	560493	560493	
D O	Thermostatic capsule 5N2, cover gasket	560494	560494	
N O	Control unit Duplex, complete	Orifice 4	560410	560410
		Orifice 13	560409	560409
		Orifice 22		560408
M O	Control unit Simplex R, complete	Orifice 4	560413	560413
		Orifice 13	560412	560412
		Orifice 22		560411
L O	Control unit Simplex, complete	Orifice 4	560416	560416
		Orifice 13	560415	560415
		Orifice 22		560414
F H	Hand-vent valve ³⁾	560058	560058 560125	
J H	Float lifting lever ³⁾	560434	560434 on request	

1) Purchasing quantity 20 pcs. For smaller quantities please contact your local dealer.

2) Purchasing quantity 10 pcs. For smaller quantities please contact your local dealer.

3) The standard cover does not feature any bores, hence it cannot be retrofitted at a later date.

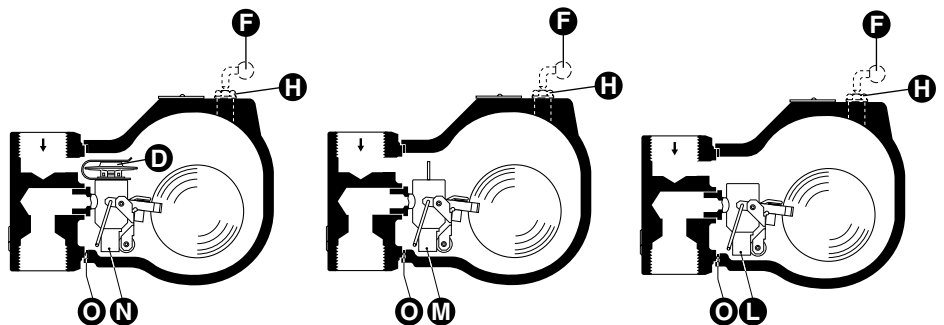

Ball Float Trap 14, PN 25
UNA 16 Carbon Steel, PN 40
UNA 16A Stainless Steel, PN 40
DN 15, 20, 25

Capacity Chart

The chart shows the maximum capacity of hot condensate for float-controlled orifices (O). The cold water capacities are: Capacity multiplied by factor F.

The capacities are dependent on the differential pressure (working pressure). The differential pressure is the difference between inlet and outlet pressures and depends among other things on the run of the condensate line. If the condensate downstream of the trap is lifted, the differential pressure (working pressure) is reduced by approximately 1 bar for 7 m (or 2 psi for 3 feet) lift.

The maximum admissible differential pressure is dependent on the cross-sectional flow area of the orifice and the density of the liquid.

The standard designs of the traps for condensate from steam are available for the following maximum differential pressures:

UNA 14: up to 4 or 13 bar.

UNA 16, 16A up to 4, 13 or 22 bar.

k _{vs} values [m ³ /h]		
DN 15 – 25	Simplex R	Duplex
Orifice 4	0.54	0.71
Orifice 13	0.33	0.51
Orifice 22	0.24	0.44
Ø of hole [mm], Orifice		
Orifice 4	4.8	
Orifice 13	3.3	
Orifice 22	2.8	

Available on request at extra cost:

Test certificate according to EN 10204/2.2 and -3.1B. All inspection requirements have to be stated with the order. After supply of the equipment certification cannot be established. For tests and inspection charges please consult us.



These products meet the requirements of the EC Pressure Equipment Directive (PED) no. 97/23/eec. This pressure equipment can be used for fluid group 2 (non-hazardous substances); UNA 16 A stainless steel can also be used for fluid group 1 (hazardous substances). DN 15-25 are excluded from the scope of the PED (according to section 3.3) and are not entitled to bear the CE marking.

Supply in accordance with our general terms of business.

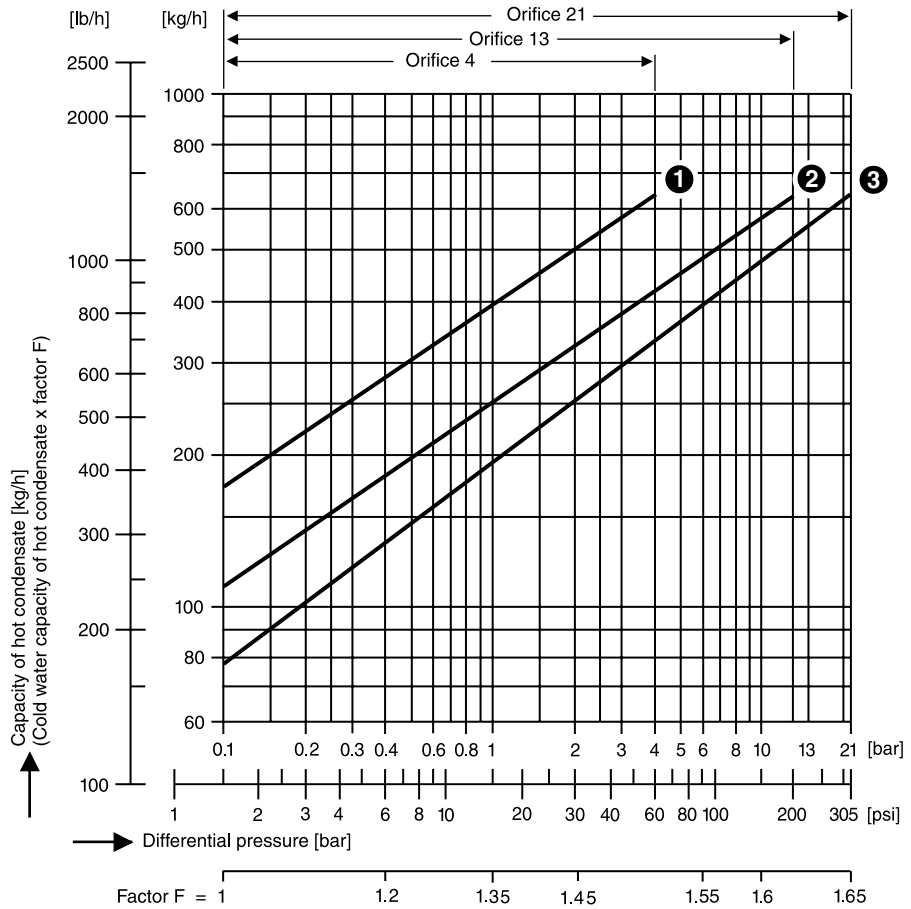

- ① Orifice 4, DN 15 - 25, ½" - 1"
- ② Orifice 13, DN 15 - 25, ½" - 1"
- ③ Orifice 21, DN 15 - 25, ½" - 1"

Additional cold-water start-up capacity due to thermostatic capsule (Duplex design)

Cold water Δp [bar]	1	2	3	4	6	8	10	13	18	22
Approx. capacity [kg/h]	180	230	330	410	480	540	600	680	760	840



GESTRA GmbH

P. O. Box 10 54 60, D-28054 Bremen
Münchener Str. 77, D-28215 Bremen

Telephone +49 (0) 421 35 03 -0, Fax +49 (0) 421 35 03 -393
E-Mail gestra.gmbh@flowserve.com, Internet www.gestra.de



Flow Control Division